

314E L CR

Hydraulic Excavator



Engine

Engine Model	Cat® C4.4 ACERT™	
Power – ISO 9249 (metric)	67 kW	91 hp

Drive

Maximum Travel Speed	5.4 km/h
Maximum Drawbar Pull	113 kN

Weights

Minimum Operating Weight	14 500 kg
Maximum Operating Weight	17 100 kg

If you are looking for a compact, productive, and fuel-efficient 14 metric ton machine, you will find it in the all new 314E L CR.

Built to meet today's European Union Stage IIIB emission standards, the 314E makes an excellent choice for people who need a well-balanced and versatile utility machine. In fact, this new model comes equipped with several new features and benefits that will please both owners and operators.

Contents

Compact Radius	4
Engine	5
Hydraulics	6
Operator Station.....	8
Structures & Undercarriage	9
Work Tools.....	10
Front Linkage	11
Integrated Technologies	12
Serviceability	13
Safety	14
Complete Customer Care.....	15
Sustainability	16
Specifications.....	17
Standard Equipment.....	30
Optional Equipment.....	31





Compact Radius

You can have flexibility and peace of mind in tight quarters.



If your work space is restricted, the 314E L CR makes an ideal choice because it can get up close to new residential construction, buildings, fences, hillsides, or any other “crowded” environment with ease.

When rotated 90 degrees and working over the side, the 314E L CR’s counterweight extends only a bit beyond the track width and doesn’t exceed the length of the track at all. This significantly reduces the risk of your operator damaging the machine and surrounding structures in full swing, which makes for a safer work environment and lower owning and operating costs for your business.

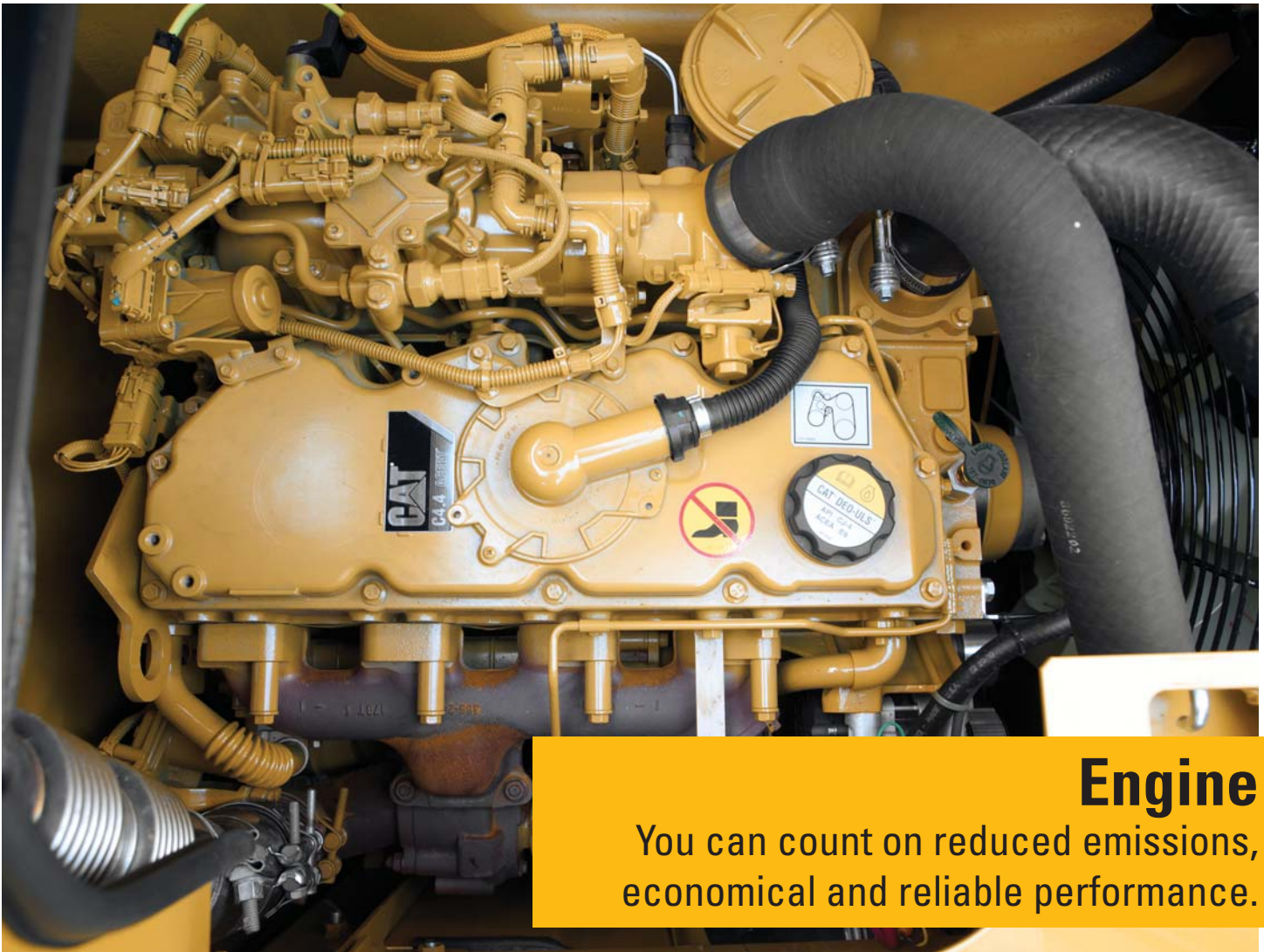

Engine

You can count on reduced emissions,
economical and reliable performance.

The Cat C4.4 ACERT engine is built to meet your demanding needs all day every day. There is no interruption to your job process as our new regeneration system works automatically with no operator intervention required.

Power Modes

The 314E features two power modes: High power mode is when you need maximum production; economy mode is when you need to balance performance with fuel economy.

Two additional fuel-saving features are on demand engine power and engine idle shutdown. On demand engine power keeps speed low during light loading and idling and automatically adjusts speed up when it senses a heavier load; engine idle shutdown automatically shuts the engine off when it's been idling for more than a specified amount of time that you set, which can save significant amounts of fuel, reduce your emissions, and even reduce your accumulated service hours, which will extend service intervals and improve re-sale value.

Biodiesel-Ready Fuel System

The C4.4 ACERT engine runs on ultra-low-sulfur diesel fuel, and you have added flexibility of running on B20 biodiesel fuel that meets ASTM 6751 standards. Just fill it up and go.

Hydraulics

You can move dirt, rock, and debris with speed, precision, and efficiency.



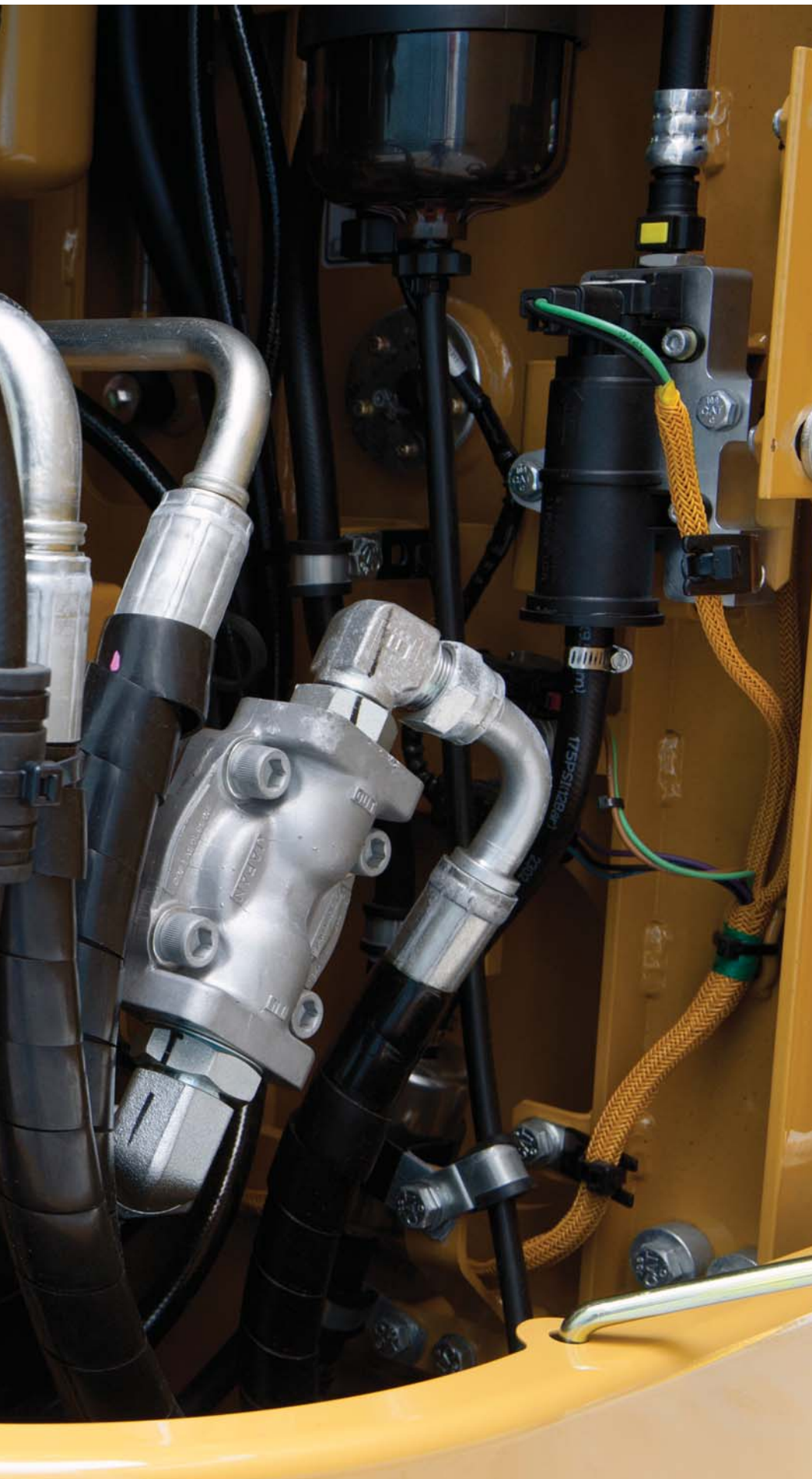

Hydraulic System

One of the biggest contributors to your productivity and fuel savings is a well-designed hydraulic system, and this is where Cat excavators stand apart. The 314E L CR is loaded with several unique features that will put more power to the ground with less money out of your pocket.

Pumps and Valves

The main control valve is built to work with any tool, allowing you to take on multiple tasks with one machine. The main pumps are located side by side and are driven directly by the engine for the highest level of efficiency to reduce your fuel costs.

Boom Regeneration

Electric boom regeneration results in less pressure loss, higher controllability, more productivity, and lower operating costs for you; it works by reusing the flow of oil that travels from the head of the boom cylinder to the rod end of the boom cylinder during your operator's everyday "boom down" operation. During boom regeneration, engine speed is controlled to be low in order to save extra oil flow from going to the boom cylinders, which saves energy.

Operator Station

Your operators will enjoy the incredibly quiet and comfortable cab.



Seats

Mechanical and air suspension seat options with heated and air-cooled availability give operators all the comfort they need for a long day of work. All seats include a reclining back, upper and lower seat slide adjustments, and height and tilt angle adjustments.

Controls

Your operators can adjust the right and left joysticks for individual preferences, helping the operator become more comfortable, more productive, and more alert.

Power Supply and Auxiliary Audio Port

To keep your operators happy, comfortable and connected, one 12-volt power supply is located on the radio near key storage areas for charging electronic devices such as an MP3 player and cell phone.

Storage

Your operators have storage spaces located in the rear. A dedicated space near the auxiliary power supply will hold an MP3 player and cell phone. The drink holder accommodates large mugs with handles, and a shelf behind the seat stores large lunch or toolboxes.

Monitor

Your operators can keep safely focused on the job at hand with a high-resolution LCD monitor that is programmable in 44 languages to support today's diverse workforce. It also projects the image from the rearview camera, further enhancing the safety and productivity of your job site.



Automatic Climate Control

An automatic climate control system features seven air outlets with filtered ventilation to make your operators comfortable in either hot or cold climates.



Structures & Undercarriage

You can take on a variety of tough tasks with this built-to-last machine.



Frame

You can expect excellent quality, reliability, and durability with the 314E L CR's reinforced lower and upper frames. Both are built to handle a hard day's work over and over again.

Undercarriage

Long undercarriage supports any type of work you can do with a 14 metric ton machine. The track rollers are a double solid-pin-type design to improve reliability; an optional two-piece guiding guard helps maintain track alignment and improves the machine's overall performance.



Counterweight

The 314E L CR has two counterweight options – 3.06 and 3.56 mt – to optimally match your machine to the task at hand, whether it's doing light trenching or heavy lifting. With integrated links, you can also easily – and safely – remove the counterweight for maintenance or shipping.

Blades

Three blades (2500, 2600 and 2700 mm) are optionally available with the 314E L CR for improved stability and lifting ability.

Work Tools

You can dig, hammer, rip, and cut with confidence.



You can extend the versatility and performance of your machine with the full lineup of Cat work tools. Each tool equips your machine to perform many different tasks found at a variety of job sites.

Couplers: Quick Tool Changes

Imagine the productivity you'll achieve with a quick coupler. Combine a robust coupler with a common work tool inventory that can be shared between same size machines, and you'll get performance and flexibility on every job.

Work Tools: Cut, Crush, Pulverize, and Load

No matter your specialty, Caterpillar provides tools that are perfectly matched to get the most out of your Cat machine – quickly and efficiently.

Buckets: Dig, Move, Load

Cat buckets are designed to fill efficiently so you notice a fast, smooth cycle which means high productivity each time you dig. Wear characteristics of General Duty, Heavy Duty and Severe Duty buckets give you solid performance in a wide variety of material abrasions. Ditch cleaning and other specialty buckets are available when needed.



Front Linkage

You'll experience a long service life even in the harshest of conditions.

Your uptime and service intervals are increased with durable and reliable booms, sticks, and linkage pins. Each boom and stick is built with internal baffle plates for additional strength, and each undergoes ultrasound inspection to ensure you get the durability and reliability you expect for any tough application.

Booms and Sticks

Three types of booms are available to meet the variety of tasks you take on in a given day.

Reach Boom – The Reach boom offers you excellent all-around versatility and a large working envelope, for any applications such as digging dirt, moving rock, and doing the nearly endless amount of tasks you can do with Cat hydraulic work tools.

The 314E L CR is offered with a reach boom and two (2) stick configurations : R2.5 m and R3.0 m.

The R3.0 m stick is best suited when you need deep trenching, longer reach, and top truck loading capabilities. The R2.5 m stick provides greater breakout force and increases productivity when you primarily plan on using hydromechanical work tools.

Variable Angle Boom – The variable angle boom offers superb flexibility and versatility in the working envelope. Boom position can be adjusted from 90° when fully retracted to 180° and fully extended.

With full extension, the working range gives maximum dig depth, reach, and working height.

When retracted, it can work closer to its tracks, increase lifting capacity, and work in confined areas, ideally suited for placing PVC pipe.

The 314E L CR can also be equipped with a variable angle boom and two (2) stick configurations : R2.1 m and R2.5 m.

Power Offset Boom – For tough-to-reach places, the 314E L CR can even be equipped with a power offset boom and a R2.13 m stick, which allows your operator to stay in the same position to load and dump, which increases productivity when your team is working in narrow, restricted space.

A bucket-to-cab avoidance feature is included to ensure safe operation.

Your Cat dealer can help you pick the best configuration for your business.

Integrated Technologies

You can make your team's work much easier and more efficient.



Cat Grade Control Depth and Slope

Cat Grade Control Depth and Slope is a standalone factory offering that allows your operator to reference a site elevation and input simple elevation and slope targets into the display to give them real-time bucket tip position through the cab monitor. This allows them to cut or fill to the target elevation the first time, which minimizes the need and cost for traditional grade checking. It also enhances job site safety and helps your team complete jobs quicker with fewer cycles, which means you'll save money on fuel.

Cat Product Link™

You can monitor and improve your fleet management with optional Cat Product Link. The integrated system reports events, diagnostic codes, hours, fuel consumption, location, and other pieces of detailed machine information to the secured web-based application called VisionLink®. The powerful tools within VisionLink communicate with you and your authorized Cat dealer to allow them to help you avoid downtime and better maintain your fleet.

Serviceability

You can depend on safe, fast, and easy access.



Ground-Level Compartments

Your service technicians have ground-level access to the radiator, pump, and air cleaner compartments through wide service doors, making it easy for them to reach, check, and replace fluids and filters.

Cooling System

The cooling package features an improved oil cooler and engine radiator design mounted side by side and the air-to-air aftercooler and A/C condenser mounted in front. The radiator uses an aluminum square wave fin to prevent clogging with the other components positioned to make cleaning cores easier – a major service convenience.

Other Service Benefits

The engine oil dipstick is conveniently located in the front of the engine compartment.

The fuel tank's remote drain cock makes it easy and simple to remove water and sediment during routine maintenance.

Risk of overfilling the fuel tank is significantly reduced with an integrated fuel level indicator.

Safety

Several built-in features will help protect your people.

Roll-Over Protective Structure (ROPS) Cab

Your operators will benefit from the enhanced protection of a ROPS-certified cab. It is also built to accommodate a Falling Object Guard Structure (FOGS) for industrial applications.

Sound Proofing

Roof lining and sealing make your operator's sound experience inside the cab comparable to any of today's top pickup trucks.

Anti-Skid Plates

Your operator and service technicians' slipping hazards are reduced with anti-skid plates on the surface of the upper structure and the top of the storage box area.

Steps, Hand and Guard Rails

Your service technicians can work securely on the machine with extended hand and guardrails to the upper deck and steps on the track frame and storage box.

Time Delay Lights

The cab and boom lights can be programmed to stay on for up to 90 seconds after the engine has been turned off to help your operators safely exit the machine.

High Intensity Discharge (HID) Lights

You can upgrade to HID lights for greater visibility in low-light conditions.

Windows

You can easily store both the upper and lower window in cab. Your overhead visibility and lighting are enhanced with a large skylight that can double as an emergency exit.

Rearview Camera

Your operator has a clear view behind the machine through the monitor with the rearview camera.





Complete Customer Care

Your Cat dealer will support you like no other.

Product Support

You can maximize your machines' uptime with the Cat worldwide dealer network. You can also decrease your repair costs by utilizing Cat remanufactured components while contributing to sustainable development.

Machine Selection

What are your job requirements and machine attachments? What production do you need? Your Cat dealer can provide recommendations to help you make the right machine configuration.

Purchase

You can ensure lower owning and operating costs by utilizing dealer services and financing options.

Customer Support Agreements

Cat dealers offer a variety of customer support agreements and work with you to develop a plan to meet your specific needs. These plans can cover the entire machine, including attachments, to help protect your investment.

Operation

You can boost your profits by improving operating techniques. Your Cat dealer has videos, literature, and other ideas to help you increase productivity. Caterpillar also offers simulators and certified operator training to help maximize the return on your investment.

Replacement

Repair, rebuild, or replace? Your Cat dealer can help you evaluate the cost involved so you can make the best choice for your business.



Sustainability

Your machine is designed to benefit generations ahead.



- The 314E L CR is an efficient, productive machine that's designed to conserve our natural resources for generations ahead.
- The C4.4 ACERT engine ensures you meet EU Stage IIIB emission standards.
- The 314E L CR has the flexibility of running on either ultra-low-sulfur diesel (ULSD) fuel with 15 ppm of sulfur or less or biodiesel (B20) fuel blended with ULSD that meets ASTM 6751 or EN 14214 standards.
- An overfill indicator rises when the fuel tank is full to help your service technicians avoid spilling.
- An unique engine oil filter eliminates the need for painted metal cans and aluminum top plates. The cartridge-style spin-on housing enables the internal filter to be separated and replaced; the used internal element can be incinerated to help reduce waste.
- You can ensure fast, easy, and secure changing of engine and hydraulic oil with the QuickEvac™ option.



314E L CR Hydraulic Excavator Specifications

Engine

Engine Model	Cat C4.4 ACERT
Power – ISO 9249	67 kW
Power – ISO 9249 (metric)	91 hp
Power – ISO 9249 (imperial)	89 hp
Power – ISO 14396	70 kW
Power – ISO 14396 (metric)	95 hp
Power – ISO 14396 (imperial)	94 hp
Bore	105 mm
Stroke	127 mm
Displacement	4.4 L

Weights

Minimum Operating Weight	14 500 kg
Maximum Operating Weight	17 100 kg

Hydraulic System

Main System – Maximum Flow (total)	254 L/min
Swing System – Maximum Flow	127 L/min
Maximum Pressure – Equipment	30 500 kPa
Maximum Pressure – Power Offset Boom (optional)	29 900 kPa
Maximum Pressure – Travel	35 000 kPa
Maximum Pressure – Swing	23 000 kPa
Pilot System – Maximum Flow	21.9 L/min
Pilot System – Maximum Pressure	4120 kPa
Boom Cylinder – Bore	110 mm
Boom Cylinder – Stroke	1000 mm
Stick Cylinder – Bore	120 mm
Stick Cylinder – Stroke	1197 mm
Bucket Cylinder – Bore	100 mm
Bucket Cylinder – Stroke	939 mm

Drive

Maximum Travel Speed	5.4 km/h
Maximum Drawbar Pull	113 kN
Gradeability	35°/70%

Swing Mechanism

Swing Speed	11.5 rpm
Swing Torque	30.9 kN·m

Service Refill Capacities

Fuel Tank Capacity	178 L
Cooling System	28 L
Engine Oil (with filter)	13.5 L
Swing Drive (each)	2.4 L
Final Drive (each)	3 L
Hydraulic System Oil Capacity (including tank)	162 L
Hydraulic Tank Oil	84 L

Track

Long Undercarriage	
Number of Shoes (each side)	46 pieces
Number of Track Rollers (each side)	7 pieces
Number of Carrier Rollers (each side)	2 pieces

Sound Performance

ISO 6396	
Operator Noise (closed)	69 dB(A)
ISO 6395	
Spectator Noise	100 dB(A)

- When properly installed and maintained, the cab offered by Caterpillar, when tested with doors and windows closed according to ANSI/SAE J1166 OCT98, meets OSHA and MSHA requirements for operator sound exposure limits in effect at the time of manufacture.
- Hearing protection may be needed when operating with an open operator station and cab (when not properly maintained or doors/windows open) for extended periods or in a noisy environment.

314E L CR Hydraulic Excavator Specifications

Dimensions

All dimensions are approximate.

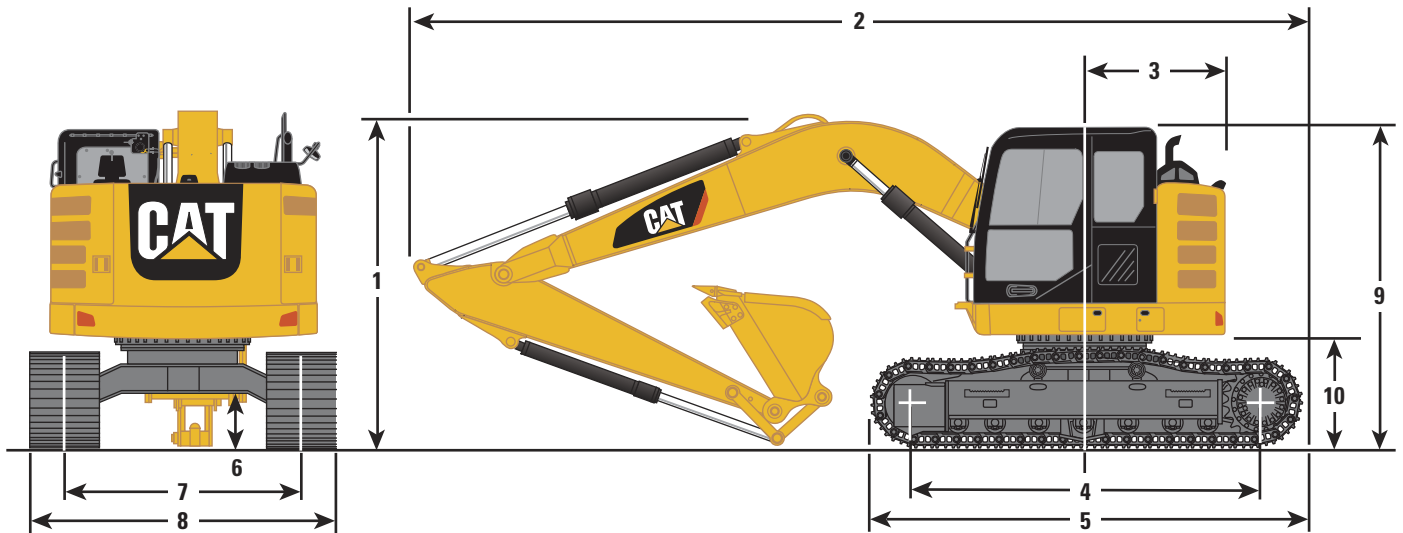

Stick	Reach Boom 4.65 m		Variable Angle Boom		Power Offset Boom
	R3.0 m	R2.5 m	R2.5 m	R2.1 m	R2.13 m
1 Shipping Height*	3000 mm	3000 mm	3000 mm	3000 mm	3000 mm
Shipping Height at Boom Top	2750 mm	2820 mm	2760 mm	2600 mm	2780 mm
Shipping Height with Guard Rail	3000 mm	3000 mm	3000 mm	3000 mm	3000 mm
Shipping Height with Top Guard	2950 mm	2950 mm	2950 mm	2950 mm	2950 mm
2 Shipping Length					
Long Undercarriage	7450 mm	7450 mm	7520 mm	7580 mm	7040 mm
Long Undercarriage with Blade	8010 mm	8010 mm	8080 mm	8140 mm	7600 mm
3 Tail Swing Radius					
Standard Counterweight	1490 mm	1490 mm	1490 mm	1490 mm	1490 mm
Heavy Counterweight	1530 mm	1530 mm	1530 mm	1530 mm	1530 mm
4 Length to Center of Rollers	3040 mm	3040 mm	3040 mm	3040 mm	3040 mm
5 Track Length	3750 mm	3750 mm	3750 mm	3750 mm	3750 mm
6 Ground Clearance	440 mm	440 mm	440 mm	440 mm	440 mm
7 Track Gauge	1990 mm	1990 mm	1990 mm	1990 mm	1990 mm
8 Transport Width					
500 mm Shoes	2490 mm	2490 mm	2490 mm	2490 mm	2490 mm
600 mm Shoes	2590 mm	2590 mm	2590 mm	2590 mm	2590 mm
700 mm Shoes	2690 mm	2690 mm	2690 mm	2690 mm	2690 mm
9 Cab Height	2810 mm	2810 mm	2810 mm	2810 mm	2810 mm
Cab Height with Top Guard	2950 mm	2950 mm	2950 mm	2950 mm	2950 mm
10 Counterweight Clearance**	860 mm	860 mm	860 mm	860 mm	860 mm
Capacity	0.53 m ³	0.53 m ³	0.68 m ³	0.68 m ³	0.53 m ³
Tip Radius	1200 mm	1200 mm	1200 mm	1200 mm	1200 mm

*Including shoe lug height.

**Without shoe lug height.

Working Ranges

All dimensions are approximate.

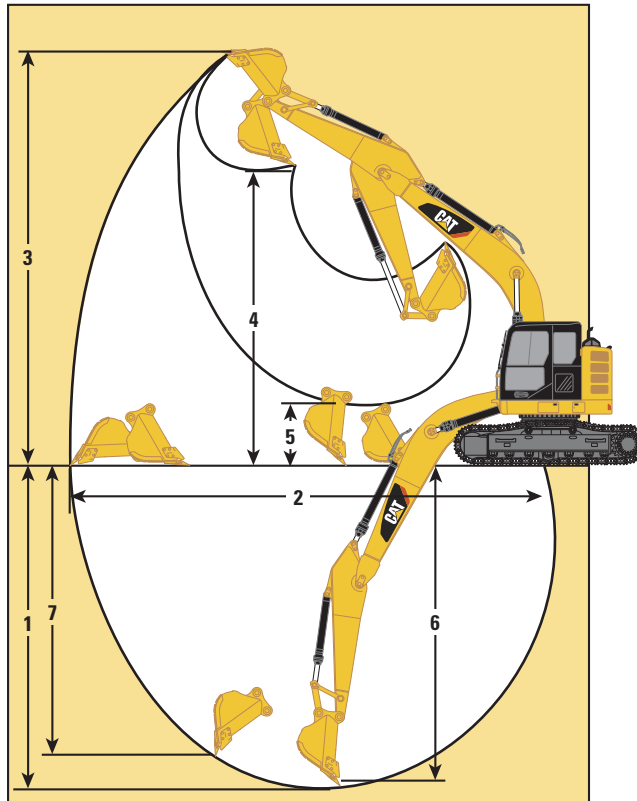

Stick	Reach Boom 4.65 m	
	R3.0 m	R2.5 m
Maximum Slope	35°/70%	35°/70%
1 Maximum Digging Depth	5950 mm	5450 mm
2 Maximum Reach at Ground Level	8680 mm	8230 mm
3 Maximum Cutting Height	9640 mm	9310 mm
4 Maximum Loading Height	7190 mm	6860 mm
5 Minimum Loading Height	2060 mm	2500 mm
6 Maximum Depth Cut for 2440 mm Level Bottom	5660 mm	5160 mm
7 Maximum Vertical Wall Digging Depth	5280 mm	4880 mm
Capacity	0.53 m ³	0.53 m ³
Tip Radius	1200 mm	1200 mm

314E L CR Hydraulic Excavator Specifications

Working Ranges

All dimensions are approximate.

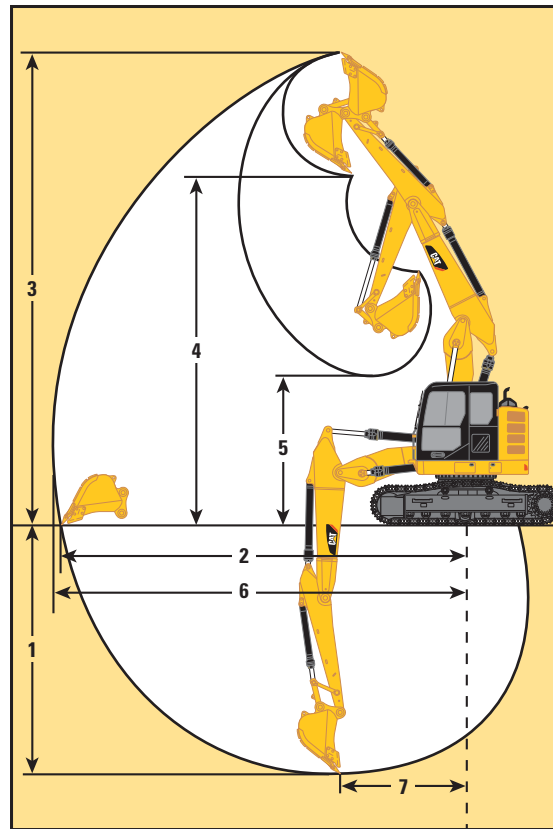

Variable Angle Boom

Stick	Variable Angle Boom	
	R2.5 m	R2.1 m
Maximum Slope	35°/70%	35°/70%
1 Maximum Digging Depth	5210 mm	4810 mm
2 Maximum Reach at Ground Level	8360 mm	7980 mm
3 Maximum Cutting Height	9810 mm	9430 mm
4 Maximum Loading Height	7400 mm	7010 mm
5 Minimum Loading Height	3050 mm	3360 mm
6 Maximum Depth Cut for 2440 mm Level Bottom	5090 mm	4680 mm
7 Maximum Vertical Wall Digging Depth	4340 mm	3920 mm
Capacity	0.53 m ³	0.53 m ³
Tip Radius	1200 mm	1200 mm

Working Ranges

All dimensions are approximate.

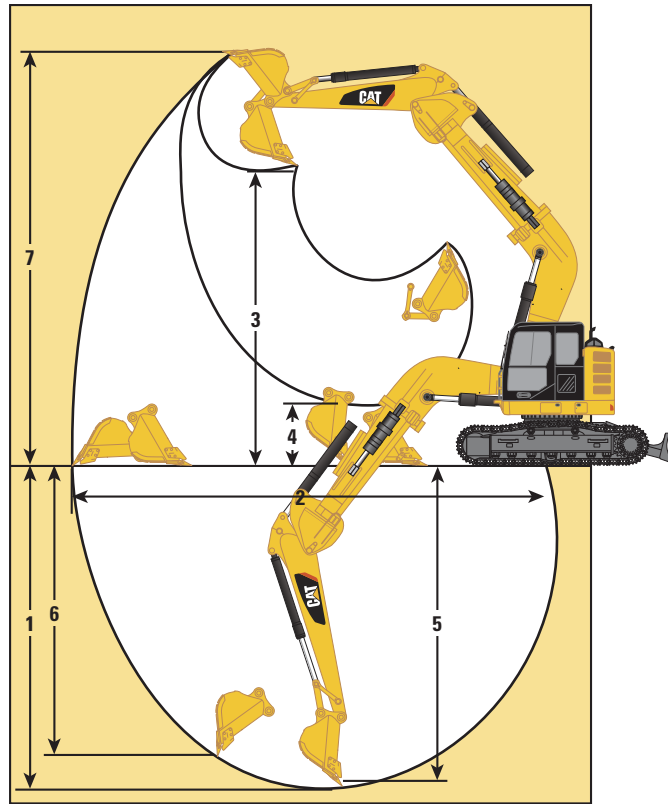

Stick	Power Offset Boom		
	R2.13 m*	R2.13 m	R2.13 m**
Maximum Slope	35°/70%	35°/70%	35°/70%
1 Maximum Digging Depth	4510 mm	4840 mm	4480 mm
2 Maximum Reach at Ground Level	6890 mm	7270 mm	6850 mm
3 Maximum Cutting Height	8110 mm	8450 mm	8070 mm
4 Maximum Loading Height	5680 mm	6020 mm	5640 mm
5 Minimum Loading Height	2330 mm	2680 mm	2290 mm
6 Maximum Depth Cut for 2440 mm Level Bottom	4110 mm	4450 mm	4080 mm
7 Maximum Vertical Wall Digging Depth	3270 mm	3550 mm	3240 mm
Capacity	0.53 m ³	0.53 m ³	0.53 m ³
Tip Radius	1200 mm	1200 mm	1200 mm

*Left side 1100 mm offset position

**Right side 1150 mm offset position

314E L CR Hydraulic Excavator Specifications

Blade Working Ranges

All dimensions are approximate.

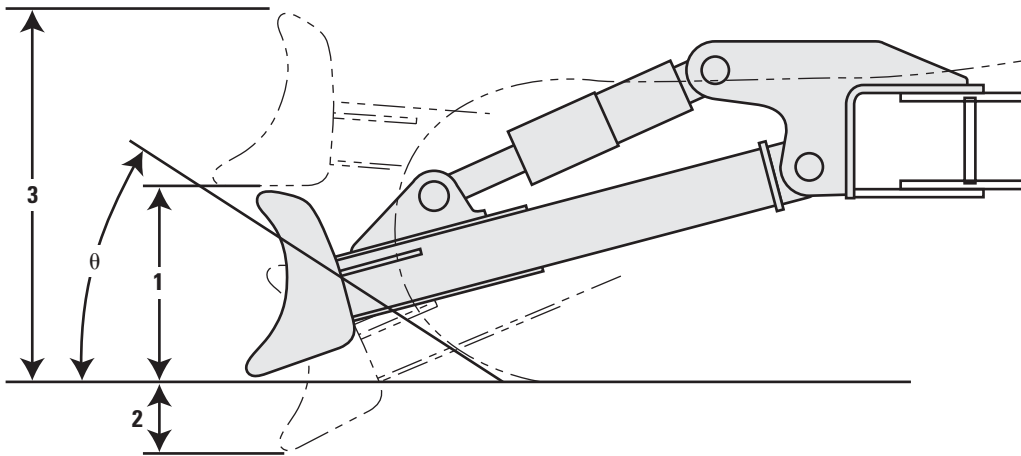

Blade Width Options	2500 mm	2600 mm	2700 mm
Recommended Track Shoe Width	500 mm	600 mm	700 mm
1 Blade Height	630 mm	630 mm	630 mm
2 Maximum Lowering Depth from Ground	570 mm	570 mm	570 mm
3 Maximum Raising Height above Ground	1000 mm	1000 mm	1000 mm
θ Approach Angle	24.9°	24.9°	24.9°

Major Component Weights

Base Machine (with boom cylinder, without counterweight, front linkage and track)	
Long Undercarriage	2660 kg
Counterweight	
Standard – 3.06 mt	3060 kg
Heavy – 3.56 mt	3560 kg
Boom (includes lines, pins and stick cylinder)	
Reach Boom – 4.65 m	1040 kg
Reach Boom for CGC – 4.65 m	1050 kg
Variable Angle Boom	1800 kg
Power Offset Boom	1730 kg
Stick (includes lines, pins, bucket cylinder and bucket linkage)	
Reach Boom	
R3.0 m	650 kg
R3.0 m for CGC	650 kg
R2.5 m	570 kg
Variable Angle Boom	
R2.5 m	640 kg
R2.1 m	650 kg
Power Offset Boom	
R2.13 m	570 kg
Track Shoe (Long/per two tracks)	
500 mm Triple Grouser	1570 kg
500 mm Triple Grouser with Rubber Pad	2080 kg
600 mm Triple Grouser	1820 kg
700 mm Triple Grouser	2090 kg
Blade	
2500 mm	810 kg
2600 mm	810 kg
2700 mm	820 kg

All weights are rounded up to nearest 10 kg. Kg were rounded up separately so some of the kg do not match.

Base machine includes 75 kg operator weight, 90% fuel weight, and undercarriage with center guard.

314E L CR Hydraulic Excavator Specifications

Operating Weight and Ground Pressure

	700 mm Triple Grouser Shoes		600 mm Triple Grouser Shoes		500 mm Triple Grouser Shoes	
Long Undercarriage without Blade, with 3.06 t Counterweight						
Reach Boom – 4.65 m						
R3.0 m	15 100 kg	32.1 kPa	14 800 kg	36.7 kPa	14 600 kg	43.5 kPa
R2.5 m	15 000 kg	31.9 kPa	14 700 kg	36.5 kPa	14 500 kg	43.2 kPa
Long Undercarriage with Blade, with 3.06 t Counterweight						
Reach Boom – 4.65 m						
R3.0 m	15 900 kg	33.8 kPa	15 600 kg	38.7 kPa	15 400 kg	45.9 kPa
R2.5 m	15 800 kg	33.6 kPa	15 600 kg	38.7 kPa	15 300 kg	45.6 kPa
Variable Angle Boom						
R2.5 m	16 600 kg	35.3 kPa	16 400 kg	40.7 kPa	16 100 kg	47.9 kPa
R2.1 m	16 600 kg	35.3 kPa	16 400 kg	40.7 kPa	16 100 kg	47.9 kPa
Power Offset Boom						
R2.13 m	16 500 kg	35.1 kPa	16 200 kg	40.2 kPa	15 900 kg	47.4 kPa
Long Undercarriage without Blade, with 3.56 t Counterweight						
Reach Boom – 4.65 m						
R3.0 m	15 600 kg	33.2 kPa	15 300 kg	38.0 kPa	15 100 kg	45.0 kPa
R2.5 m	15 500 kg	33.0 kPa	15 200 kg	37.7 kPa	15 000 kg	44.7 kPa
Long Undercarriage with Blade, with 3.56 t Counterweight						
Reach Boom – 4.65 m						
R3.0 m	16 400 kg	34.9 kPa	16 100 kg	40.0 kPa	15 900 kg	47.4 kPa
R2.5 m	16 300 kg	34.7 kPa	16 100 kg	40.0 kPa	15 800 kg	47.1 kPa
Variable Angle Boom						
R2.5 m	17 100 kg	36.4 kPa	16 900 kg	41.9 kPa	16 600 kg	49.4 kPa
R2.1 m	17 100 kg	36.4 kPa	16 900 kg	41.9 kPa	16 600 kg	49.4 kPa
Power Offset Boom						
R2.13 m	17 000 kg	36.2 kPa	16 700 kg	41.4 kPa	16 400 kg	48.8 kPa

Bucket and Stick Forces

Stick	Reach Boom 4.65 m		Variable Angle Boom		Power Offset Boom
	R3.0 m	R2.5 m	R2.5 m	R2.1 m	R2.13 m
General Duty					
Bucket Digging Force (ISO)	95 kN	95 kN	95 kN	95 kN	87 kN
Stick Digging Force (ISO)	58 kN	65 kN	65 kN	74 kN	63 kN
General Duty					
Bucket Digging Force (ISO)	95 kN	95 kN	95 kN	95 kN	87 kN
Stick Digging Force (ISO)	58 kN	65 kN	65 kN	74 kN	63 kN
Heavy Duty					
Bucket Digging Force (ISO)	95 kN	95 kN	95 kN	95 kN	87 kN
Stick Digging Force (ISO)	58 kN	65 kN	65 kN	74 kN	63 kN
Severe Duty					
Bucket Digging Force (ISO)	95 kN	95 kN	95 kN	95 kN	87 kN
Stick Digging Force (ISO)	58 kN	65 kN	65 kN	74 kN	63 kN
CB-Family Bucket for CW-20					
General Duty					
Bucket Digging Force (ISO)	83 kN	82 kN	82 kN	82 kN	76 kN
Stick Digging Force (ISO)	56 kN	62 kN	62 kN	70 kN	60 kN
Heavy Duty					
Bucket Digging Force (ISO)	83 kN	82 kN	82 kN	82 kN	76 kN
Stick Digging Force (ISO)	56 kN	62 kN	62 kN	70 kN	60 kN
CB-Family Bucket for CW-20S					
General Duty					
Bucket Digging Force (ISO)	83 kN	82 kN	82 kN	82 kN	76 kN
Stick Digging Force (ISO)	56 kN	62 kN	62 kN	70 kN	60 kN
Heavy Duty					
Bucket Digging Force (ISO)	83 kN	82 kN	82 kN	82 kN	76 kN
Stick Digging Force (ISO)	56 kN	62 kN	62 kN	70 kN	60 kN

Caterpillar recommends using appropriate work tools to maximize the value customers receive from our products. Use of work tools, including buckets, which are outside of Caterpillar's recommendations or specifications for weight, dimensions, flows, pressures, etc. may result in less-than-optimal performance, including but not limited to reductions in production, stability, reliability, and component durability. Improper use of a work tool resulting in sweeping, prying, twisting and/or catching of heavy loads will reduce the life of the boom and stick.

314E L CR Hydraulic Excavator Specifications

Reach Boom Lift Capacities – Heavy Counterweight: 3.56 mt – No Blade

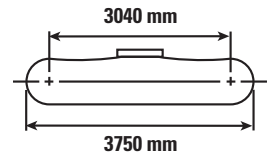
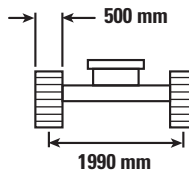
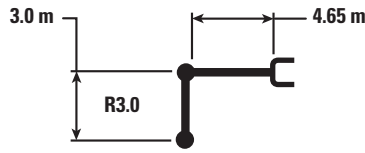

		1.5 m		3.0 m		4.5 m		6.0 m		7.5 m		m		
7.5 m	kg					*2600	*2600					*2500	*2500	4.54
6.0 m	kg					*3450	*3450	*2350	*2350			*2100	*2100	6.07
4.5 m	kg					*3700	*3700	*3400	2550			*2000	*2000	6.96
3.0 m	kg			*5900	*5900	*4350	3850	*3650	2500			*2000	1750	7.43
1.5 m	kg			*8050	6450	*5150	3600	3800	2350	*2500	1700	*2100	1650	7.58
0.0 m	kg			*7350	6050	*5600	3350	3650	2250			*2300	1700	7.43
-1.5 m	kg	*4550	*4550	*8050	5950	*5400	3250	3600	2200			*2700	1850	6.94
-3.0 m	kg	*7550	*7550	*6450	6000	*4500	3250	*2950	2250			*2850	2200	6.04
-4.5 m	kg			*3550	*3550							*2150	*2150	4.49

Reach Boom Lift Capacities – Heavy Counterweight: 3.56 mt – No Blade

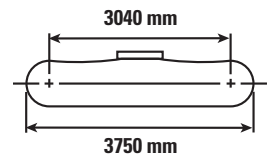
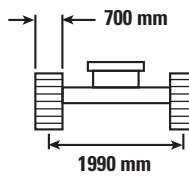
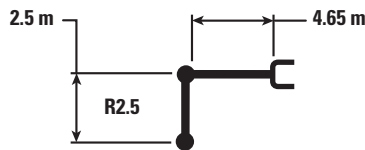

		1.5 m		3.0 m		4.5 m		6.0 m		7.5 m		m		
7.5 m	kg			*4450	*4450							*3050	*3050	3.74
6.0 m	kg					*3900	*3900					*2400	*2400	5.51
4.5 m	kg			*4550	*4550	*4100	*4100	*3700	2650			*2250	*2250	6.47
3.0 m	kg			*6800	*6800	*4750	3900	*3850	2550			*2250	2000	6.98
1.5 m	kg			*7250	6550	*5450	3650	3900	2450			*2350	1900	7.14
0.0 m	kg			*6550	6250	*5700	3500	3850	2400			*2600	1950	6.97
-1.5 m	kg	*4950	*4950	*7600	6250	*5300	3450	*3750	2350			*3150	2150	6.45
-3.0 m	kg	*7600	*7600	*5700	*5700	*4050	3500					*2900	2700	5.47



ISO 10567



*Indicates that the load is limited by hydraulic lifting capacity rather than tipping load. The above loads are in compliance with hydraulic excavator lift capacity standard ISO 10567:2007. They do not exceed 87% of hydraulic lifting capacity or 75% of tipping load. Weight of all lifting accessories must be deducted from the above lifting capacities. Lifting capacities are based on the machine standing on a firm, uniform supporting surface. The use of a work tool attachment point to handle/lift objects, could affect the machine lift performance.

Lift capacity stays with ±5% for all available track shoes.

Always refer to the appropriate Operation and Maintenance Manual for specific product information.

Variable Angle Boom Lift Capacities – Heavy Counterweight: 3.56 mt – Blade Up

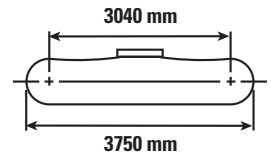
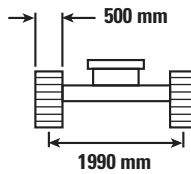
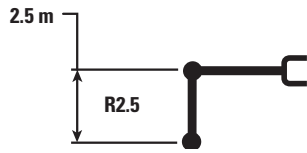

		1.5 m		3.0 m		4.5 m		6.0 m		7.5 m		m		
7.5 m	kg											*2900	*2900	3.98
6.0 m	kg					*3200	*3200					*2350	*2350	5.67
4.5 m	kg			*4850	*4850	*4250	4200	*2250	*2250			*2200	*2200	6.61
3.0 m	kg			*6600	*6600	*4150	3950	*2350	*2350			*2150	1900	7.11
1.5 m	kg	*4200	*4200	*6950	6450	*4850	3600	*2550	2400			*2250	1800	7.27
0.0 m	kg	*4150	*4150	*6100	6050	5550	3400	*3050	2300			*2450	1850	7.11
-1.5 m	kg	*6300	*6300	*6250	6050	*4850	3300	*3350	2250			*2550	2000	6.60
-3.0 m	kg	*10 650	*10 650	*4650	*4650	*2950	*2950					*2450	*2450	5.35

Variable Angle Boom Lift Capacities – Heavy Counterweight: 3.56 mt – Blade Up

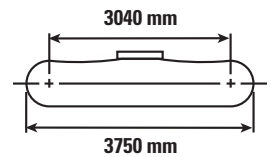
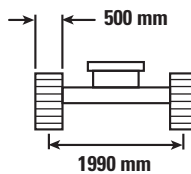
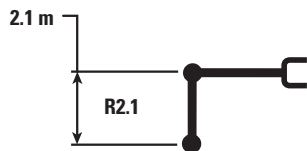

		1.5 m		3.0 m		4.5 m		6.0 m		7.5 m		m		
7.5 m	kg			*3700	*3700							*3700	*3700	3.21
6.0 m	kg					*2950	*2950					*2850	*2850	5.17
4.5 m	kg			*6350	*6350	*4200	4100	*2750	2550			*2600	2400	6.19
3.0 m	kg			*6550	*6550	*4350	3850	*2850	2500			*2600	2050	6.72
1.5 m	kg			*6500	6300	*5200	3500	*3050	2350			*2700	1950	6.89
0.0 m	kg	*5450	*5450	*5450	*5450	5500	3350	3600	2250			*2950	1950	6.72
-1.5 m	kg	*8050	*8050	*5250	*5250	*4400	3300	*2800	2250			*2500	2200	6.17
-3.0 m	kg			*4700	*4700	*3000	*3000					*2950	*2950	4.58



ISO 10567



*Indicates that the load is limited by hydraulic lifting capacity rather than tipping load. The above loads are in compliance with hydraulic excavator lift capacity standard ISO 10567:2007. They do not exceed 87% of hydraulic lifting capacity or 75% of tipping load. Weight of all lifting accessories must be deducted from the above lifting capacities. Lifting capacities are based on the machine standing on a firm, uniform supporting surface. The use of a work tool attachment point to handle/lift objects, could affect the machine lift performance.

Lift capacity stays with ±5% for all available track shoes.

Always refer to the appropriate Operation and Maintenance Manual for specific product information.

314E L CR Hydraulic Excavator Specifications

Power Offset Boom Lift Capacities – Standard Counterweight: 3.06 mt – Blade Up

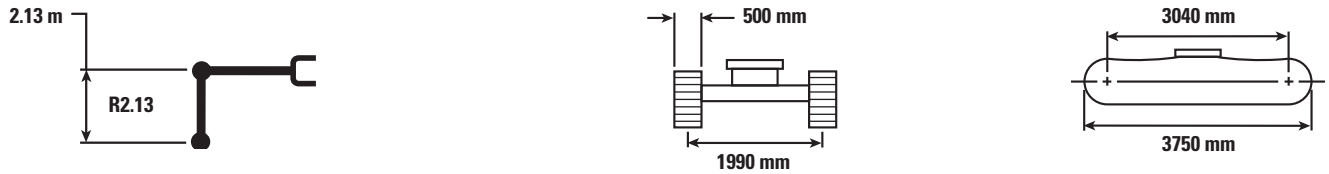

Reach (m)	kg	1.5 m		3.0 m		4.5 m		6.0 m		7.5 m		m		
		Hydraulic Hammer	Mobile Scrap and Demolition Shear	Hydraulic Hammer	Mobile Scrap and Demolition Shear	Hydraulic Hammer	Mobile Scrap and Demolition Shear	Hydraulic Hammer	Mobile Scrap and Demolition Shear	Hydraulic Hammer	Mobile Scrap and Demolition Shear			
6.0 m	kg			*4550	*4550							*2750	*2750	4.20
4.5 m	kg			*5000	*5000	*4150	3900					*2650	*2650	5.41
3.0 m	kg			*6600	*6600	*4600	3650	*3000	2300			*2750	2300	6.02
1.5 m	kg			*8050	5900	*5150	3350	3450	2200			*3100	2050	6.21
0.0 m	kg			*7850	5500	5150	3100	3350	2100			3350	2100	6.01
-1.5 m	kg	*6300	*6300	*6650	5500	*4650	3000					*3700	2350	5.39
-3.0 m	kg			*4400	*4400							*3300	*3300	4.16



ISO 10567



*Indicates that the load is limited by hydraulic lifting capacity rather than tipping load. The above loads are in compliance with hydraulic excavator lift capacity standard ISO 10567:2007. They do not exceed 87% of hydraulic lifting capacity or 75% of tipping load. Weight of all lifting accessories must be deducted from the above lifting capacities. Lifting capacities are based on the machine standing on a firm, uniform supporting surface. The use of a work tool attachment point to handle/lift objects, could affect the machine lift performance.

Lift capacity stays with ±5% for all available track shoes.

Always refer to the appropriate Operation and Maintenance Manual for specific product information.

Work Tool Offering Guide*

Boom Type	Reach Boom	
	R3.0 m	R2.5 m
Stick Size		
Hydraulic Hammer	H110Es H115Es	H110Es H115Es
Mobile Scrap and Demolition Shear	S320B**	S320B**
Compactor (Vibratory Plate)	CVP75	CVP75
Demolition and Sorting Grapple	G310B	G310B
Digging Grapple	GG525	GG525
Orange Peel Grapple	GSM22	GSM22
Trash Grapple		
Thumbs		
Rakes		
Universal CW Coupler		

These work tools are available for the 314E L CR.
Consult your Cat dealer for proper match.

*Matches are dependent on excavator configurations. Consult your Cat dealer for proper work tool match.

**Boom Mount.

Bucket Specifications and Compatibility

	Width	Capacity	Weight	Fill	Reach Booms		VAB		POB*
	mm	m ³	kg	%	R3.0 m	R2.5 m	R2.5 m	R2.1 m	R2.13 m
Without Quick Coupler									
General Duty (GD)	600	0.31	315	100%	●	●	●	●	●
	750	0.41	362	100%	●	●	●	●	●
	900	0.53	411	100%	●	●	●	●	●
	1000	0.60	436	100%	⊙	●	●	●	●
	1100	0.68	470	100%	⊖	⊙	●	●	●
	1200	0.76	499	100%	x	x	⊙	⊙	●
Heavy Duty (HD)	450	0.20	276	100%	●	●	●	●	●
	1200	0.76	506	100%	○	⊖	⊙	⊙	●
Maximum load pin-on (payload + bucket)				kg	1570	1780	1845	1985	2225

	Width	Capacity	Weight	Fill	Reach Booms		VAB		POB*
	mm	m ³	kg	%	R3.0 m	R2.5 m	R2.5 m	R2.1 m	2.13 m
With Center-Lock™ Quick Coupler									
General Duty (GD)	600	0.31	328	100%	●	●	●	●	●
	900	0.53	423	100%	⊙	●	●	●	●
	1100	0.68	482	100%	○	⊖	⊖	⊙	●
	1200	0.76	511	100%	◇	○	⊖	⊖	⊙
Heavy Duty (HD)	1200	0.76	511	100%	◇	○	⊖	⊖	⊙
Maximum load with coupler (payload + bucket)				kg	1359	1569	1634	1774	2014

The above loads are in compliance with hydraulic excavator standard EN474, they do not exceed 87% of hydraulic lifting capacity or 75% of tipping capacity with front linkage fully extended at ground line with bucket curled.

Capacity based on ISO 7451.

Bucket weight with Long tips.

*POB installs blade as standard configuration.

Maximum Material Density:

- 2100 kg/m³
- ⊙ 1800 kg/m³
- ⊖ 1500 kg/m³
- 1200 kg/m³
- ◇ 900 kg/m³
- x Not recommended

Caterpillar recommends using appropriate work tools to maximize the value customers receive from our products. Use of work tools, including buckets, which are outside of Caterpillar's recommendations or specifications for weight, dimensions, flows, pressures, etc. may result in less-than-optimal performance, including but not limited to reductions in production, stability, reliability, and component durability. Improper use of a work tool resulting in sweeping, prying, twisting and/or catching of heavy loads will reduce the life of the boom and stick.

Standard Equipment

Standard equipment may vary. Consult your Cat dealer for details.

CAB

- Pressurized operator station with positive filtration
- Sliding upper door window (left-hand cab door)
- Glass-breaking safety hammer
- Removable lower windshield with in cab storage bracket
- Coat hook
- Beverage holder
- Literature holder
- Two stereo speakers
- Storage shelf suitable for lunch or toolbox
- Color LCD display with indicators, filter/fluid change, and working hour information
- Adjustable armrest
- Height adjustable joystick consoles
- Neutral lever (lock out) for all controls
- Travel control pedals with removable hand levers
- Capability of installing additional pedal
- Power outlets, 5 amp
- Travel alarm
- Laminated glass front window, 70/30 split (tempered glass for bottom front window)
- Seatbelt, 2 inch
- Cab mirror
- Windshield wipers

ELECTRICAL

- 80 amp alternator
- Circuit breaker
- Capability to electrically connect a beacon

ENGINE

- C4.4 ACERT diesel engine EU Stage IIIB
- Biodiesel capable
- EU Stage IIIB emission standards
- 2300 m altitude capability
- Electric priming pump
- Automatic engine speed control
- Economy and high power modes
- Two-speed travel
- Side-by-side cooling system
- Radial seal air filter
- Primary filter with water separator and water separator indicator
- Secondary filter
- Screen filter in fuel line
- Standard battery –18° C
- Variable speed fan with viscous clutch

HYDRAULIC SYSTEM

- Regeneration circuit for boom and stick
- Reverse swing dampening valve
- Automatic swing parking brake
- High-performance hydraulic return filter
- Boom lowering and stick lowering check valves

LIGHTS

- Working lights, cab mounted
- Halogen boom light (left side)
- Time delay function for boom light and cab light
- Exterior light

UNDERCARRIAGE

- Center track guiding guard
- Grease Lubricated Track GLT2, resin seal
- Towing eye on base frame
- Heavy duty bottom guard
- Swivel guard

SECURITY

- Cat one key security system
- Door locks
- Cap locks on fuel and hydraulic tanks
- Lockable external tool/storage box
- Signaling/warning horn
- Secondary engine shutoff switch
- Rear window for emergency exit
- Guard rail and handrail
- Guard, travel motor protection
- Bottom guards, heavy duty
- Rearview camera

Optional Equipment

Optional equipment may vary. Consult your Cat dealer for details.

CAB

- Seat, high-back air suspension with heater and cooling
- Seat, high-back air suspension with heater
- Seat, high-back mechanical suspension
- Rain protector

COUNTERWEIGHT

- 3.06 mt without lifting eye
- 3.56 mt without lifting eye

ELECTRICAL

- Cold weather battery –25° C
- Jump start receptacle

ENGINE

- Quick drains, engine and hydraulic oil

FRONT LINKAGE

- Reach boom
 - R3.0 m stick
 - R2.5 m stick
- Variable Angle boom
 - R2.1 m stick
 - R2.5 m stick
- Power Offset boom
 - R2.13 m stick
- Bucket, lifting eye
- Universal Quick Coupler

HYDRAULIC SYSTEM

- Auxiliary hydraulics
- Boom and stick high pressure lines
- Boom and stick medium-pressure lines
- Boom and stick Universal Quick Coupler lines
- Cat Bio hydraulic oil

LIGHTS

- HID light, cab mounted with time delay
- Halogen boom lights (right side)

UNDERCARRIAGE

- 500 mm triple grouser shoes
- 500 mm rubber pads triple grouser shoes
- 600 mm triple grouser shoes
- 700 mm triple grouser shoes
- 2500 mm blade with replaceable cutting edge
- 2600 mm blade with replaceable cutting edge
- 2700 mm blade with replaceable cutting edge
- Two-piece, segmented track guiding guards
- Swivel guard

SECURITY

- FOGS, bolt-on
- Guard, cab front, mesh
- Security system fitted (MSS)
- Bottom guards, standard

TECHNOLOGY

- Cat Grade Control Depth and Slope
- Product Link

For more complete information on Cat products, dealer services, and industry solutions, visit us on the web at www.cat.com

© 2013 Caterpillar Inc.
All rights reserved

AEHQ6949 (08-2013)
(Europe)

Materials and specifications are subject to change without notice. Featured machines in photos may include additional equipment. See your Cat dealer for available options.

CAT, CATERPILLAR, SAFETY.CAT.COM, their respective logos, "Caterpillar Yellow" and the "Power Edge" trade dress, as well as corporate and product identity used herein, are trademarks of Caterpillar and may not be used without permission.

VisionLink is a trademark of Trimble Navigation Limited, registered in the United States and in other countries.

